

FEATURES

- Configurable input for RTD, mV, Resistance and Potentiometer
- 4 ÷ 20 mA configurable output on current loop
- Configurable by Personal Computer
- High accuracy
- On-field reconfigurable
- EMC compliant – CE mark
- Suitable for DIN B in-head mounting
- Option for DIN rail mounting in compliance with EN 50022 (DIN RAIL Option)



GENERAL DESCRIPTION

The transmitter DAT 1010 is able to execute many functions such as : measure and linearisation of the temperature characteristic of RTDs sensors, conversion of a linear resistance variation, conversion of a voltage signal even coming from a potentiometer connected on its input. The measured values are converted in a 4÷20 mA current signal . The device guarantees high accuracy and performances stability both in time and in temperature. The programming of the DAT 1010 is made by a Personal Computer using the software PROSOFT, developed by DATEXEL, that runs under the operative system "Windows™". By use of PROSOFT, it is possible to configure the transmitter to interface it with the most used sensors . In case of sensors with a no-standard output characteristic, it is possible to execute, via software, a "Custom" linearisation (per step) to obtain an output linearised signal . For Resistance and RTDs sensors it is possible to program the cable compensation with 3 or 4 wires. It is possible to set the minimum and maximum values of input and output ranges in any point of the scale, keeping the minimum span shown in the table below. Moreover it is available the option of alarm for signal interruption (burn-out) that allows to set the output value as high or low out of scale . The DAT 1010 is in compliance with the standard 89/336/CEE on the Electromagnetic Compatibility. It is housed in a self-extinguish plastic enclosure suitable for DIN B in-head mounting. Moreover (by proper mounting kit) it is possible to mount the DAT 1010 on DIN rail.

USER INSTRUCTIONS

The transmitter DAT 1010 must be powered by a direct voltage between 10 to 32 V and applied to the terminals +V and -V. The 4÷20 mA output signal is measurable in the power loop as shown in the section "Output/Power supply connections"; Rload is the input impedance of instruments on the current loop; to obtain a correct measure, the value of Rload will be calculated as function of the power supply value (see section "Technical specification – Load characteristic"). The input connections must be made as shown in the section "Input connections". To configure, calibrate and install the transmitter refer to sections " DAT1010: configuration and calibration" and "Installation Instructions".

TECHNICAL SPECIFICATIONS (Typical at 25 °C and in nominal conditions)

Input type	Min	Max	Min. span		
RTD(*) 2,3,4 wires				Input calibration (1)	Response time (10+ 90%) about 400 ms
Pt100	-200°C	850°C	50°C	RTD	> of ±0.1% f.s. or ±0.2°C
Pt1000	-200°C	200°C	50°C	Low res.	> of ±0.1% f.s. or ±0.15 Ω
Ni100	-60°C	180°C	50°C	High res.	> of ±0.2% f.s. or ±1 Ω
Ni1000	-60°C	150°C	50°C	mV	> of ±0.1% f.s. or ±18 μV
Voltage				Output calibration	Power supply
mV	-100mV	+700mV	2 mV	Current	± 7 μA
Potentiometer				Input impedance	Power supply voltage 10 .. 32 Vdc
(Nominal value)	0 Ω	200 Ω	10%	mV	>= 10 MΩ
	200 Ω	500 Ω	10%	Linearity (1)	Reverse polarity protection 60 Vdc max
	0.5 KΩ	2 KΩ	10%	RTD	± 0.1 % f.s.
RES. 2,3,4 wires				Line resistance influence	Load characteristic - Rload (maximum load value on current loop per power supply value)
Low	0 Ω	300 Ω	10 Ω	mV	<=0,8 μV/Ohm
High	0 Ω	2000 Ω	200 Ω	RTD 3 wires	0.05%/Ω (50 Ω balanced max.)
				RTD 4 wires	0.005%/Ω (100 Ω balanced max.)
Output type	Min	Max	Min. span	RTD excitation current	Temperature & humidity
Direct current	4 mA	20 mA	4 mA	Typical	0,350 mA
Reverse current	20 mA	4 mA	4 mA	Thermal drift (1)	Operative temperature -20°C .. +70°C
				Full scale	± 0.01% / °C
				Burn-out values	Storage temperature -40°C .. +85°C
				Max. value	about 22.5 mA
				Min. value	about 3.6 mA
					Humidity (not condensed) 0 .. 90 %
					Housing
					Material Self-extinguish plastic
					Mounting DIN B head or bigger
					Weight about 50 g.
					Dimensions Ø = 43 mm ; H = 24 mm
					EMC (for industrial environments)
					Immunity EN 61000-6-2
					Emission EN 61000-6-4

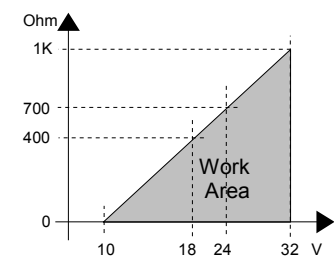

(1) referred to input Span (difference between max. and min. values)

(*) For temperature sensors it is possible to set the input range also in F degrees; to made the conversion use the formula: °F = (°C*9/5)+32)

DAT 1010: CONFIGURATION AND CALIBRATION

Warning: during these operations the device must always be powered.

- CONFIGURATION

- 1) Power-on the DAT1010 by a direct voltage between $10 \div 32$ V or (only to configure) by a 9 V battery .
- 2) Remove the protection plastic cap on DAT 1010.
- 3) Connect the interface PRODAT to the Personal Computer and to device. (see section " DAT1010: PROGRAMMING").
- 4) Run the software PROSOFT.
- 5) Set the parameters of configuration .
- 6) Program the device.

- CALIBRATION CONTROL

With software PROSOFT running:

- 1) Connect on the input a calibrator setted with minimum and maximum values referred to the electric signal or to the temperature sensor to measure.
- 2) Set the calibrator at the minimum value.
- 3) Verify that the DAT 1010 provides on output the minimum setted value.
- 4) Set the calibrator at the maximum value.
- 5) Verify that the DAT 1010 provides on output the maximum setted value.
- 6) In case of regulation of value obtained in the step 3 and 5, use the ZERO and SPAN regulators of software PROSOFT. The variation introduced from these regulators must be calculated as percentage of the input range .
- 7) Program the device with the new parameters .

DAT 1010: PROGRAMMING

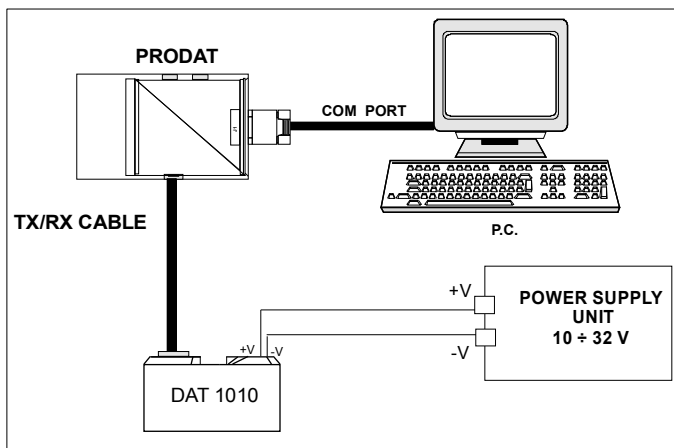

DIN B in-head mounting

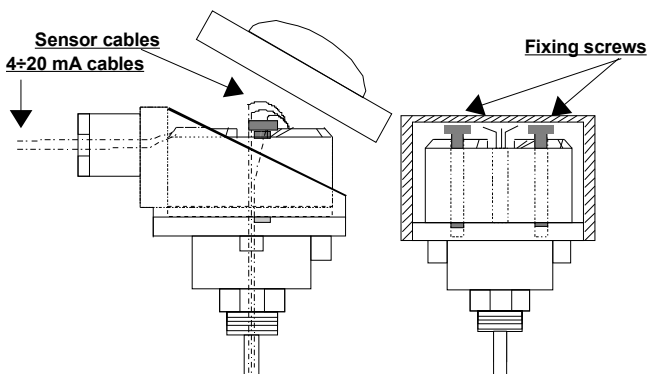

DIN rail mounting (DIN RAIL Option)

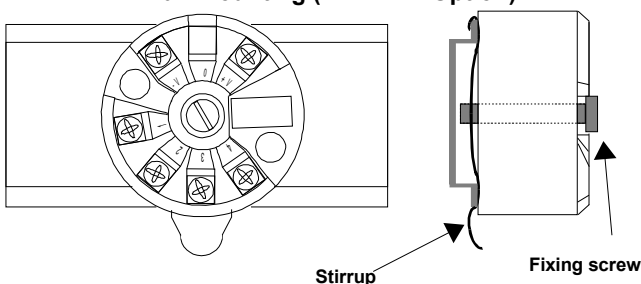

INSTALLATION INSTRUCTIONS

The device DAT 1010 is suitable for direct DIN B in-head mounting. The transmitter must be fixed inside the probe by the proper kit.

By apposite stirrup, provided on request, it is possible to mount the device on DIN rail in compliance with EN-50022. It is necessary to install the device in a place without vibrations; avoid to routing conductors near power signal cables .

DAT1010: CONNECTIONS

INPUT CONNECTIONS

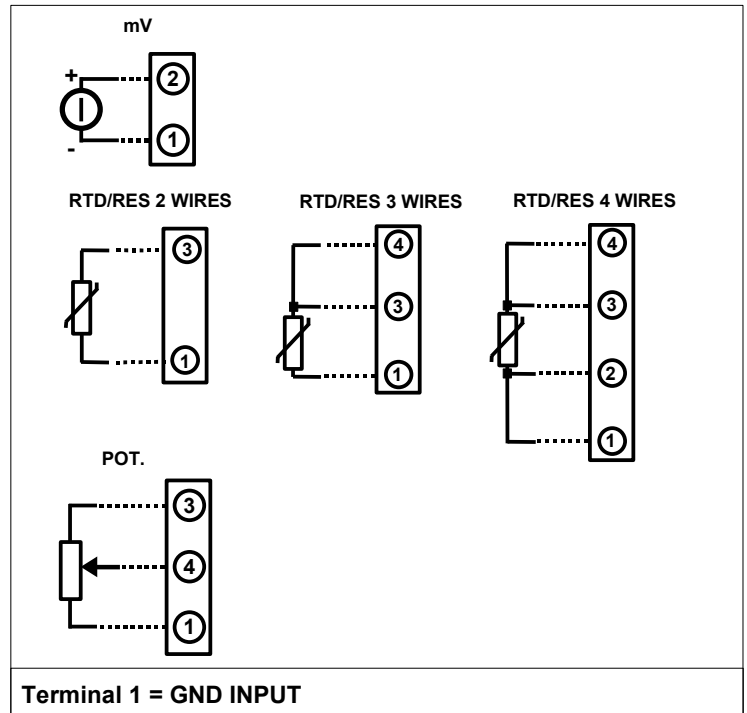

OUTPUT/POWER SUPPLY CONNECTIONS

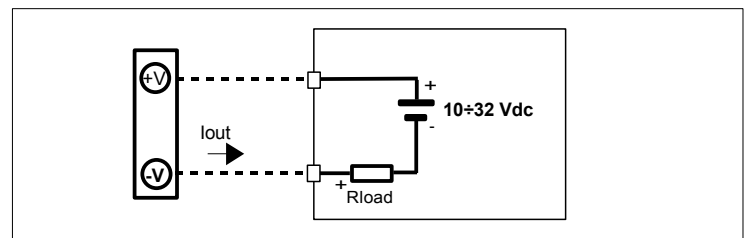

MECHANICAL DIMENSIONS (mm)

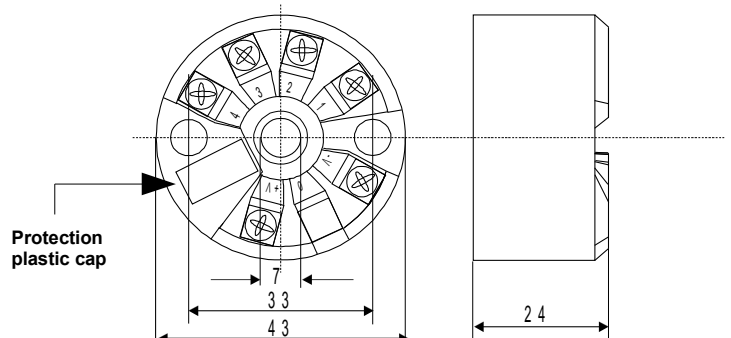

HOW TO ORDER

The DAT1010 is provided as requested on the Customer's order. Refer to the section "Technical specification" to determine input and output ranges. The mounting kit for DIN rail is provided **only on request** with code DIN RAIL. In case of the configuration is not specified, the parameters must be set by the user.

ORDER CODE EXAMPLE:

