

Pneumatic Positioner Type 3766

Electropneumatic Positioner Type 3767



Application

Single-acting or double-acting positioners for attachment to pneumatic control valves. Supplied with a pneumatic input signal 0.2 to 1 bar or 3 to 15 psi (Type 3766) or an electric input signal from 4(0) to 20 mA or 1 to 5 mA (Type 3767).

Rated travels from 7.5 to 120 mm or opening angle up to 90°



The positioners ensure a fixed assignment between the valve stem position (controlled variable x) and the pneumatic or electric input signal (reference variable w). They compare the input signal received from the control unit with the travel of the control valve and, issue the corresponding output signal pressure p_{st} (output variable y). A reversing amplifier for double-acting actuators produces two opposed signal pressures.

Special features

- Arbitrary mounting position; suitable for normal or split-range operation; excellent dynamic response; negligibly small influence of supply air; adjustable proportional band (P-band); adjustable air output capacity; low air supply consumption; very insensitive to mechanical vibrations; low-maintenance compact design
- Versions for hazardous areas in type of protection "Intrinsic Safety" Ex i II 2 G EEx ia IIC T6 or Ex n II 3 G EEx nA II T6 for Zone 2 (see "Summary of approvals")
- Type of protection "Flameproof Enclosure" EEx d with Type 3766 Positioner and Type 6116 i/p Converter (Fig. 2)
- Special version with CrNiMo steel housing available
- Direct attachment to Type 3277 Pneumatic Actuator (Fig. 4)
- Attachment to actuators according to IEC 60534-6 (Fig. 3)
- Attachment to rotary actuators acc. to VDI/VDE 3845 (Fig. 5)

Benefits of integral positioner attachment (Fig. 4)

- Tight and exact mechanical connection between actuator and positioner. No misalignment during shipping
- Concealed linkage protected against touch and external influences to fulfill requirements of accident prevention regulations UVV (VBG 5)
- Simple pneumatic connection between actuator and positioner
- Presetting of the unit: Actuator with positioner

Optional pressure gauge for monitoring the input and output signal pressure (dial range from 0 to 6 bar and 0 to 90 psi).

Refer to Information Sheet T 8350 EN for details on the selection and application of positioners, converters, limit switches and solenoid valves.

Versions

- **Type 3766** · Pneumatic positioner
- **Type 3767** · Electropneumatic positioner

Refer to article code for details on possible configurations.

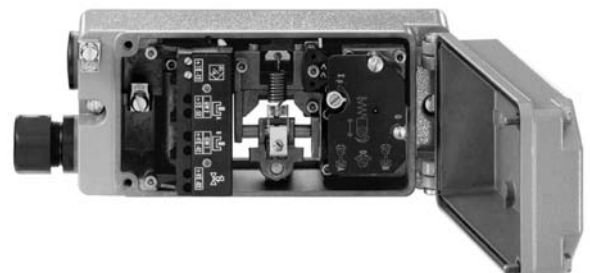

Fig. 1 · Type 3767 Electropneumatic Positioner



Fig. 2 · Type 3766 Ex d Positioner with Type 6116 i/p Converter



Fig. 3 · Attachment acc. to IEC 60534 (NAMUR)

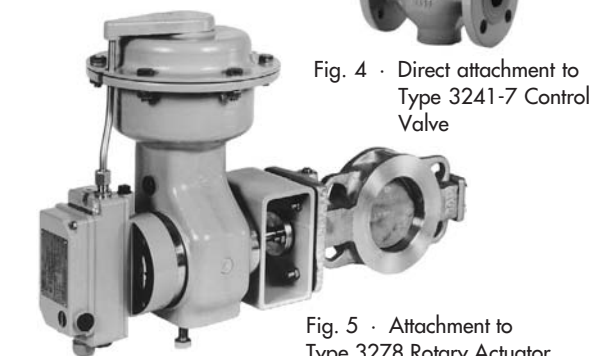

Fig. 4 · Direct attachment to Type 3241-7 Control Valve



Fig. 5 · Attachment to Type 3278 Rotary Actuator

Principle of operation (Figs. 6 to 8)

The only difference between the two positioners is an i/p converter unit (E) in the electropneumatic positioner. Both positioners function according to the force-balance principle.

In the Type 3767 Electropneumatic Positioner, the control signal (i) flows through the plunger coil (E2) in the field of a permanent magnet (E1). The force, proportional to the DC current i, is balanced against the force of the backpressure at the balance beam (E3) which is created at the flapper plate (E7) by the jet stream leaving the nozzle (E6). Any changes in the signal cause a proportional change in the pressure p_e supplied to the pneumatic control system.

The pressure p_e creates a force at the measuring diaphragm (5) which is compared to the force of the range spring (4). If the control signal causes the pneumatic input pressure (p_e) or the position of the lever (1) to change, the diaphragm lever (3) functioning as a flapper plate varies the distance to the nozzle (2.1 or 2.2). The position of the internal turnboard for the operating direction (7) determines which nozzle is effective.

The pneumatic booster (10) and the pressure regulator (9) are provided with supply air. The controlled supply flows against the diaphragm lever (3) over the X_p restriction (8) and the nozzle (2.1 or 2.2). Any changes in the control signal or the position of the lever (1) cause a variation of pressure both upstream and downstream of the booster (10). The output signal pressure p_{st} issued by the booster flows over the volume restriction (11) to the actuator and positions the valve to match the input signal.

The travel is transmitted to the pick-up lever (1) via the pin (1.1) in globe valves. Whereas, in rotary valves (Fig. 8), a cam follower roll (20) is attached to the front end of the pick-up lever (1) which follows the rotary motion of a cam disk (22) on the actuator shaft (21). The force of the range spring (4) is changed by the linear motion of pick-up lever.

The positioner must be fitted with a reversing amplifier for attachment to double-acting actuators, which generates two opposed signal pressures (p_{st1} and p_{st2}).

The adjustable restrictions X_p (8) and Q (11) are used to optimize the control loop. Two adjusting screws (6.1 and 6.2) allow the adaptation of the control valve to the signal pressure. ZERO and SPAN of the reference variable can be adjusted for different operating modes, such as split-range operation.

Operating direction: As the reference variable (p_e) increases, the output signal pressure (p_{st}) can either be increasing (direct >>) or decreasing (reverse <<). The operating direction is determined by the position of the turnboard (7) and can be changed subsequently.

Legend for Figs. 6 to 8

| | |
|-------------------------------|----------------------|
| 1 Lever | E i/p converter unit |
| 1.1 Pin | E1 Permanent magnet |
| 1.2 Rotary shaft | E2 Plunger coil |
| 2.1 Nozzle (>>) | E3 Balance beam |
| 2.2 Nozzle (<<) | E4 Universal joint |
| 3 Diaphragm lever (flapper) | E5 Spring |
| 4 Range spring | E6 Nozzle |
| 5 Measuring diaphragm | E7 Flapper plate |
| 6.1 Adjusting screw (SPAN) | E8 Restriction |
| 6.2 Adjusting screw (ZERO) | E9 Damping |
| 7 Turnboard for op. direction | E10 Protective diode |
| 8 X_p restriction (gain) | 20 Cam follower roll |
| 9 Pressure regulator | 21 Actuator shaft |
| 10 Booster | 22 Cam disk |
| 11 Volume restriction Q | |
| 12 Solenoid valve (optional) | |

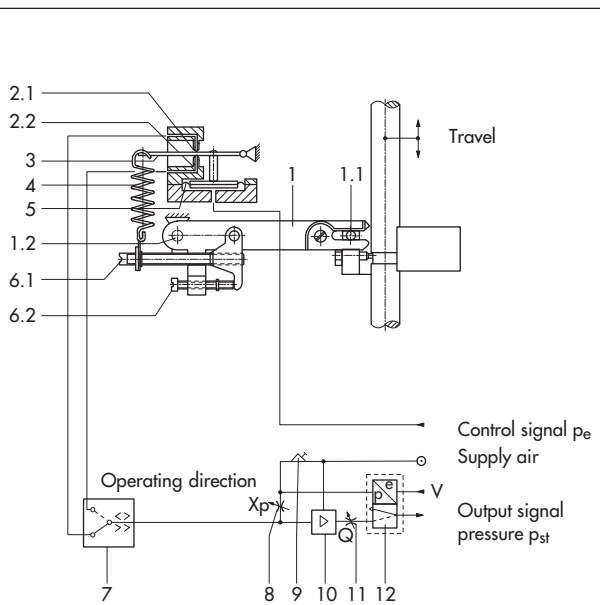

Fig. 6 · Functional diagram of Type 3766 Positioner (deflection of pick-up lever in case of direct attachment to Type 3277 Pneumatic Actuator)

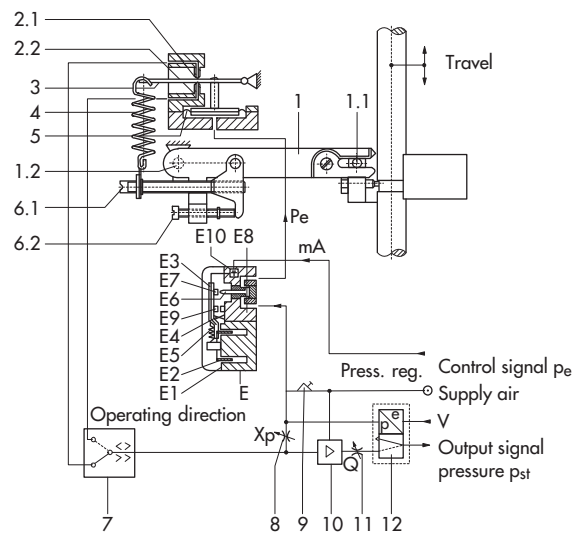

Fig. 7 · Functional diagram of Type 3767 Positioner

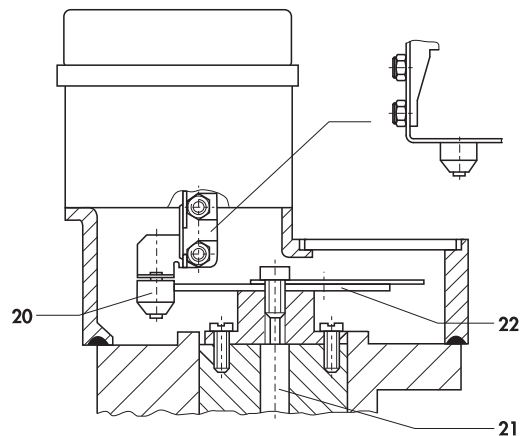

Fig. 8 · Transmission of rotary motion to the positioner

Table 1 · Technical data · All pressures in bar (gauge)

| Type 3766 and Type 3767 Positioners | | | |
|--|---|--|--|
| Travel range | | Direct attachment to Type 3277 Actuator: 7.5 ... 30 mm Attachment acc. to IEC 60534 (NAMUR): 7.5 ... 120 mm | |
| Opening angle | | 70°, 75° or 90° depending on cam disk | |
| Reference variable | Signal range | bar (psi) 0.2 ... 1 bar (3 ... 15 psi) | |
| | Span | bar (psi) 0.4 ... 0.8 bar (6 ... 12 psi) | |
| Type 3766 | Overloadabe | max. 2 bar (29 psi) | |
| Reference variable | Signal range | Two-wire device, reverse polarity protection | |
| | | Type 3766 | 4(0) ... 20 mA |
| Type 3767 | Span | 8 ... 20 mA | 2 ... 4 mA |
| | Internal resistance R _i at 20 °C | 200 Ω | 880 Ω |
| Supply air | Supply air range | 1.4 ... 6 bar (20 ... 90 psi) | |
| | Air quality acc. to ISO 8573-1 (2001-02) | Maximum particle size and density: Class 4 · Oil contents: Class 3; Pressure dew point: Class 3 or at least 10 K below the lowest ambient temperature to be expected | |
| Output signal pressure p _{st} | | Can be limited between 0 ... approx. 2.5 and 0 ... 6 bar (0 ... approx. 35 and 0 ... 90 psi) | |
| Characteristic | | Linear Deviation from terminal-based conformity: ≤ 1 % | |
| Hysteresis | | ≤ 0.3 % | |
| Sensitivity | | ≤ 0.1 % | |
| Operating direction | | Reversible | |
| Proportional band X _p | | 0.5 ... 2.5 % (proportional-action coefficient K _p : > 200 ... 40) | |
| Air consumption | With air supply of 1.4 bar | | With air supply of 6 bar |
| | Type 3766 | ≤ 230 l _n /h | ≤ 230 l _n /h ¹⁾ |
| Type 3767 | ≤ 280 l _n /h | ≤ 280 l _n /h ¹⁾ | |
| Air delivery | Actuator filled with air | 3.0 m _n ³ /h | 8.5 m _n ³ /h |
| | Actuator vented | 4.5 m _n ³ /h | 14.0 m _n ³ /h |
| Permissible ambient temperature ⁷⁾ | Type 3766 | Standard | -20...80 °C: Optional limit switches/solenoid valve/position transmitter with plastic cable gland |
| | | Low temperature version | -40...80 °C: Optional limit switches/solenoid valve with metal cable gland |
| | Type 3767 | Standard | -50...80 °C: Optional limit switches/solenoid valve with metal cable gland |
| | | Low temperature version | -20...80 °C: Optional limit switches/solenoid valve/position transmitter with plastic cable gland |
| | | | -40...80 °C: Optional limit switches/solenoid valve with metal cable gland |
| | | | -45...80 °C: Optional limit switches/solenoid valve with metal cable gland |
| Influence | | Temperature: ≤ 0.3 %/10 K · Supply air: ≤ 1 % between 1.4 ... 6 bar | |
| Electromagnetic compatability | | Requirements specified in EN 61000-6-2 and EN 61000-6-3 are met | |
| Vibrations | | No influence between 10 und 150 Hz and 4 g | |
| Explosion protection ²⁾ | | Type of protection Ⓢ II 2 G EEx ia IIC T6 or Ⓢ II 3 G EEx nA II T6 for Zone 2 | |
| Degree of protection | | IP 54 (special version IP 65) | |
| Weight | | Approx. 1 kg | |
| Additional equipment | | | |
| Limit switches | | | |
| 2 inductive proximity switches | | Type SJ 2-SN | |
| Control circuit | | Specifications corresponding to the connected transistor relay | |
| Hysteresis at rated travel | | ≤ 1 % | |
| Solenoid valve | | | |
| Input | | Binary DC voltage signal | |
| Nominal signal | | 6 V DC | 12 V DC 24 V DC |
| Signal "0" (off) ³⁾ | | ≤ 1.2 V | ≤ 2.4 V ≤ 4.7 V |
| Signal "1" (on) ⁴⁾ | | ≥ 5.4 V | ≥ 9.6 V ≥ 18.0 V |
| Maximum permissible signal | | 28 V | 25 V 32 V |
| Internal resistance R _i at 20 °C | | 2909 Ω | 5832 Ω 11714 Ω |
| Air consumption in steady state | | In addition to the positioner "Off" ≤ 60 l _n /h · "On" ≤ 10 l _n /h ¹⁾ | |
| Closing time for rated travel and signal pressure range (Kvs 0.14) | Type 3277 Actuator | 120 cm ² | 240 cm ² 350 cm ² 700 cm ² |
| | 0.2 ... 1 bar | ≤ 0.5 s | ≤ 0.8 s ≤ 1.1 s ≤ 4 s |
| | 0.4 ... 2 bar | ≤ 0.5 s | ≤ 2 s ≤ 2.5 s ≤ 8 s |
| | 0.6 ... 3 bar | 6) | ≤ 1 s ≤ 1.5 s ≤ 5 s |
| Analog position transmitter | | | |
| Output | | Two-wire device 4 ... 20 mA | |
| Auxiliary power | | Minimum terminal voltage: 12 V maximum: 45 V | The position transmitter may only be connected to a certified intrinsically safe circuit ⁵⁾ |

1) With pressure regulator at minimum setting

2) Refer to Table 2 for explosion-protected version

3) DC voltage signal at -25 °C

4) DC voltage signal at +80 °C

5) e.g. over SAMSOMATIC 994-0103-KFD2-STC4-Ex1 Loop Isolator

 6) Actuator 120 cm² for all signal pressure ranges: ≤ 0.5 s

7) The limits specified in the EC Type Examination Certificate additionally apply to explosion-protected devices.

Table 2 · Technical data for Type of Protection EEx ia IIC

| i/p converter (Type 3767 only) | | | | | |
|--|---|--------|--------|-----|----|
| Maximum values for | For connection to certified intrinsically safe circuits | | | | |
| U_0 | 28 V | | 25 V | | |
| I_0 | 85 mA | 100 mA | 120 mA | | |
| P | 0.7 W | 0.7 W | 0.7 W | | |
| Internal inductance and capacitance are negligibly small | | | | | |
| Inductive proximity switches | | | | | |
| Maximum values for | For connection to certified intrinsically safe circuits | | | | |
| U_0 | 16 V | | | | |
| I_0 | 52 mA/25 mA | | | | |
| P | 169 mW/64 mW | | | | |
| Internal inductance | $L_i = 100 \mu\text{H}$ | | | | |
| Internal capacitance | $C_i = 30 \text{ nF}$ | | | | |
| Solenoid valve | | | | | |
| Nominal signal | 6 V | 12 V | 24 V | | |
| Maximum values for | For connection to certified intrinsically safe circuits | | | | |
| U_0 (V) | 25 | 27 | 28 | 30 | 32 |
| I_0 (mA) | 150 | 125 | 115 | 100 | 90 |
| Internal inductance and capacitance are negligibly small | | | | | |
| Analog position transmitter | | | | | |
| Maximum values for | For connection to certified intrinsically safe circuits | | | | |
| U_0 | 28 V | | | | |
| I_0 | 115 mA | | | | |
| P | 1 W | | | | |
| C_i | 5.3 nF | | | | |
| Internal inductance negligibly small | | | | | |
| Permissible ambient temperatures | | | | | |
| Specifications as stated in the EC Type Examination Certificate PTB 01 ATEX 2167 and the Statement of Conformity PTB 01 ATEX 2170 X. | | | | | |

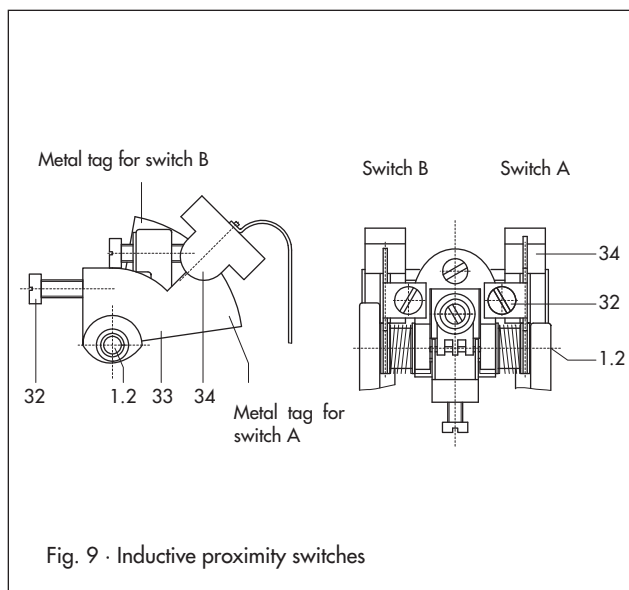

Additional equipment

The positioners can optionally be equipped with the following additional equipment.

Positioner with inductive proximity switches (Fig. 9)

This positioner version has a rotary shaft (1.2) with two adjustable metal tags (33) for inductively actuating the proximity switches (34). The switches are continuously adjustable and can be overridden.

To operate them, corresponding transistor relays must be connected in the output circuit.

The proximity switches can also be retrofitted.

Positioner with solenoid valve (Fig. 10)

The positioners can be fitted with an intrinsically safe, pilot-operated solenoid valve also in combination with the inductive limit switches. When the positioner is equipped with this solenoid valve, the control valve can be moved to the fail-safe position regardless of the positioner's output signal.

The solenoid valve essentially consists of an electropneumatic converter (12.1) and a 3/2-way solenoid valve (12.2). If a control signal corresponding to the binary signal 0 (off) is applied to the input, the nozzle (12.3) of the electropneumatic converter is opened, the signal pressure p_{st} is blocked and air is vented out of the actuator. The force of the compression springs in the actuator move the control valve to its fail-safe position.

If a control signal corresponding to binary signal 1 (on) is applied to the input, the relay coil (12.4) is energized, and the flapper plate (12.5) closes the nozzle (12.3). The increasing cascade pressure switches over the 3/2-way valve (12.2). In this switching position, the output signal pressure p_{st} is applied to the actuator. The control valve is in control operation.

The solenoid valve can also be retrofitted.

Legend to Figs. 9 and 10

- 1.2 Rotary shaft
- 12 Solenoid valve
- 12.1 i/p converter
- 12.2 3/2-way valve
- 12.3 Nozzle
- 12.4 Relay coil
- 12.5 Flapper plate
- 12.6 Restriction
- 32 Adjusting screw
- 33 Metal tag
- 34 Proximity switch

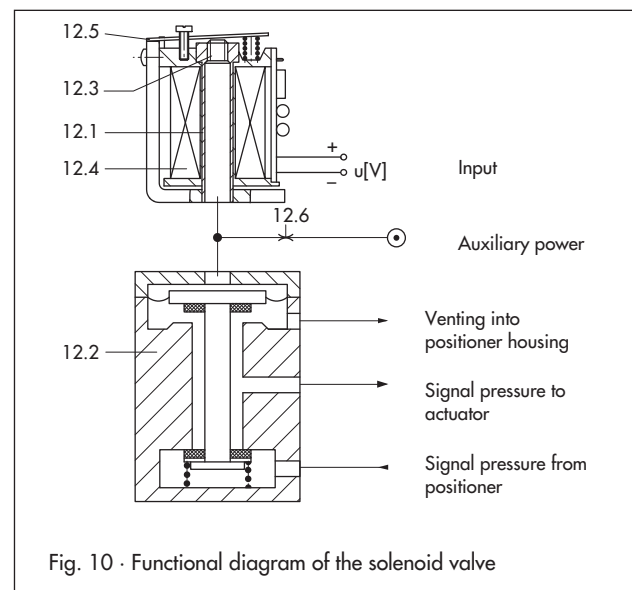

Positioner with analog position transmitter

Due to the amount of space that the position transmitter requires, please note that this option cannot be combined with limit switches or a solenoid valve!

The position transmitter allows the position of the closure member of the valve (i.e., valve travel or opening angle) to be converted into a proportional output signal from 4 to 20 mA. Limit positions such as "Valve open" or "Valve closed" are indicated as well as all intermediate positions.

Attachment (Figs. 12 and 13)

The positioner can be attached to linear actuators either directly (Type 3277 Pneumatic Actuator) or according to IEC 60534 (NAMUR) (Type 3271 Pneumatic Actuator). Rotary actuators with an interface according to VDI/VDE 3845 require an intermediate piece to mount the positioner.

Arrangement of the positioner and the actuator (Fig. 11)

How the positioner and actuator can be arranged depends on the operating direction of the input signal (p_e) and the output signal pressure (p_{st}) as well as the fail-safe action of the actuator:

"Actuator stem extends"

"Actuator stem retracts"

Direct attachment to Type 3277 Pneumatic Actuator (Fig. 4)

This method of attachment provides the benefit of being a self-contained, preset actuator and positioner unit. A connection block is required for direct attachment to actuators with 240, 350 and 700 cm² effective diaphragm areas (Fig. 11).

With an actuator with fail-safe action "Actuator stem extends", the output signal pressure p_{st} issued by the positioner is routed to the bottom diaphragm case over the connection block and a hole in the actuator yoke. In case the spring chamber needs be filled with the exhaust air from the positioner, the air can be connected to the connection block using a ready-made pipe.

With an actuator with fail-safe action "Actuator stem retracts" the output signal pressure p_{st} issued by the positioner is connected to the top diaphragm case over a ready-made pipe. The bottom diaphragm chamber (spring chamber) can be filled with the exhaust air from the positioner without additional measures over an internal hole.

The signal pressure connection is located at the back of the positioner for Type 3277-5 Pneumatic Actuator (120 cm² diaphragm area), therefore eliminating the need for external piping.

Table 3 · Direct attachment: Assignment of travel and range spring

| Actuator size in cm ² | Travel in mm | Range spring |
|----------------------------------|--------------|--------------|
| 120/240/350 | 7.5 | 2 |
| 120/240/350 | 15 | 1 |
| 700 | 15 | 2 |
| 700 | 30 | 1 |

The positioner is delivered with range spring 1. Range spring 2 is included in the accessories.

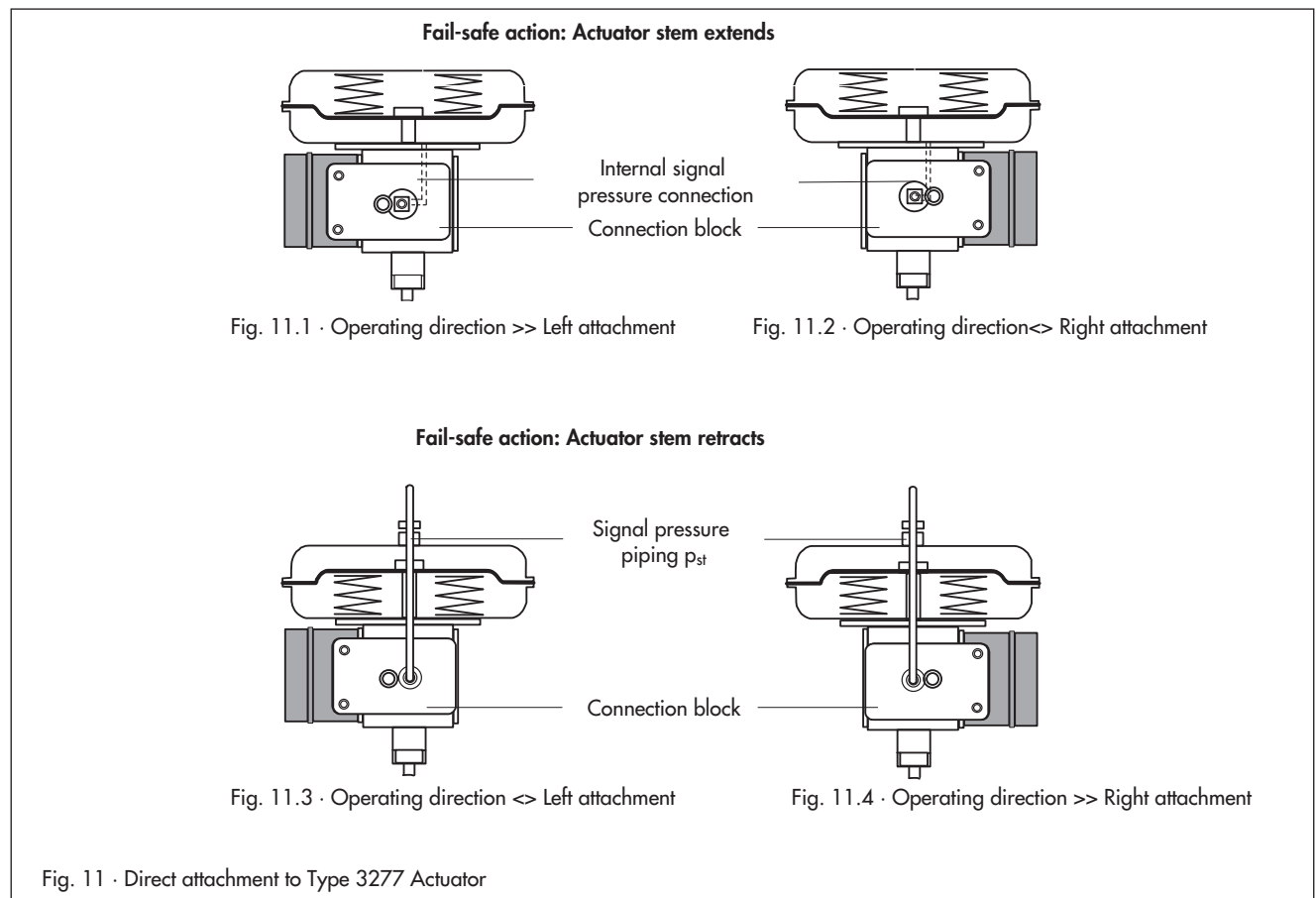

Attachment according to IEC 60534 (Figs. 3 and 12)

The positioners can be attached to actuators with cast yokes (Fig. 3) (e.g. Series 240, 250 and 280) and valves with rod-type yokes (Fig. 12) using an adapter (15). A clamping plate (15.1) is additionally required for valves with rod-type yokes.

By selecting the appropriate lever (1) and link point on the lever (16), the positioners can be matched to different travels ranging from 7.5 to 120 mm.

There is no prescribed mounting position for the positioner. The operating direction is determined by how the positioner and the adapter are arranged and how the internal turnboard is positioned.

Select the range spring according to Table 4.

Table 4 · Assignment of travel and range spring for attachment according to IEC 60534

| Travel mm | Range spring |
|----------------|--------------|
| $7.5 \leq 15$ | 2 |
| $> 15 \leq 60$ | 1 |
| $22 \leq 120$ | 1 |

The positioner is delivered with range spring 1. Range spring 2 is included in the accessories.

Attachment to rotary actuators (Fig. 13)

The positioners can be attached to the Type 3278 Rotary Actuator or any rotary actuators with an interface according to VDI/VDE 3845 over an intermediate piece (2). The rotary motion of the actuator is converted into a linear motion required by the positioner by the cam disk (7). A cam follower roll (3) is attached to the lever (5) of the positioner to trace the motion of the cam disk. Various cam disks are available depending on the control valve characteristic required (e.g. linear or equal percentage).

Double-acting, springless actuators require additionally a pneumatic reversing amplifier which produces two opposed signal pressures.

Select the range spring as follows:

Reference variable for split-range operation: Range spring 1

Reference variable for normal signal range: Range spring 2

The positioner is always delivered with range spring 1; range spring 2 is included in the mounting kit for rotary actuators.

Legend for Fig. 13

| | | | |
|---|------------------------------|------|------------------|
| 1 | Positioner | 8 | Actuator shaft |
| 2 | Intermediate piece | 9 | Plate |
| 3 | Lever with cam follower roll | 10 | Mounting bracket |
| 4 | Adapter | 11 | Coupling |
| 5 | Feedback lever | 15 | Adapter |
| 6 | Scale | 15.1 | Plate |
| 7 | Cam disk | 16 | Slide |

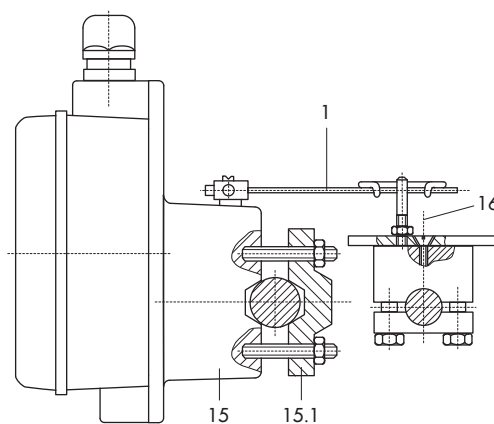

Fig. 12 · Attachment to valves with rod-type yoke

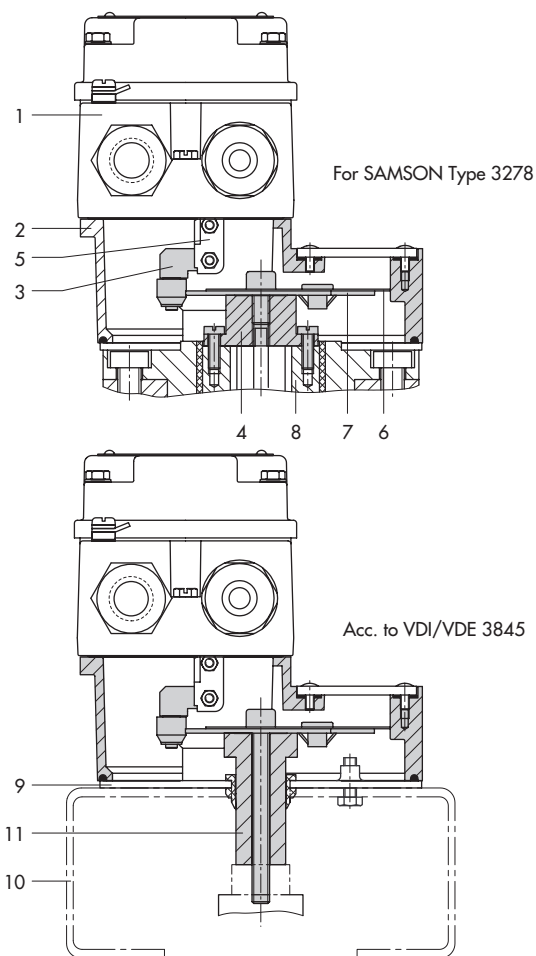

Fig. 13 · Attachment to rotary actuators

Materials

| | |
|---------------------|---|
| Housing | Die-cast aluminum chromated and plastic coated |
| Special version | CrNiMo steel, 1.4404 (316 L) |
| External parts | Stainless steel 1.4571 1.4305 |
| Measuring diaphragm | Fluorosilicone rubber |

Electrical connections

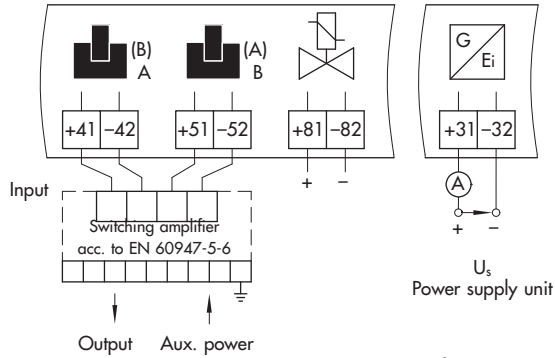
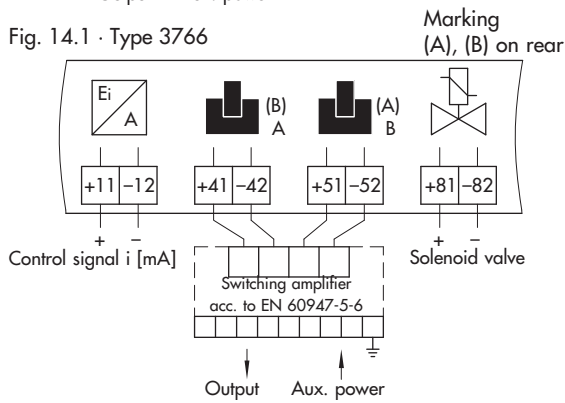

Fig. 14.1 · Type 3766



Control signal i [mA] Power supply unit for optional
position transmitter

Fig. 14.2 · Type 3767

Dimensions in mm

Direct attachment to
Type 3277 Actuator

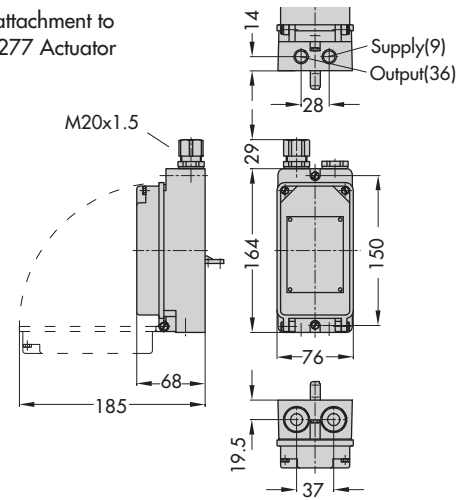

Attachment acc. to
IEC 60534
and NAMUR

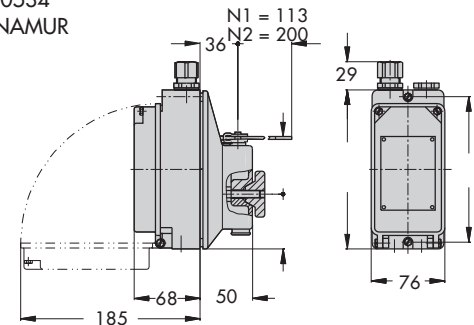

Attachment to rotary actuators
(with pneum. reversing amplifier)

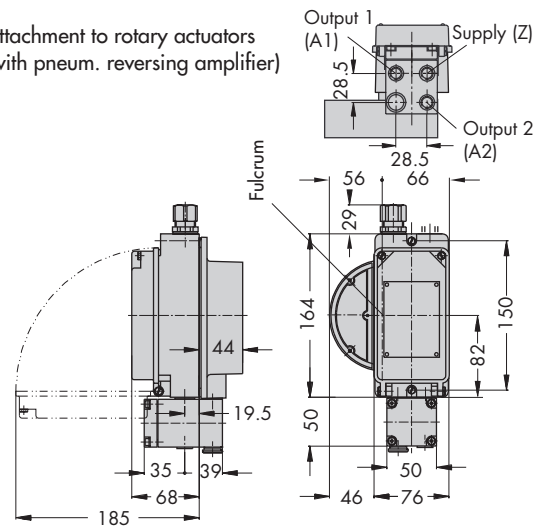

Summary of explosion protection approvals for Type 3766 Positioner

| Type of approval | Certificate number | Date | Comments |
|---------------------------------|---------------------|------------|---|
| EC Type Examination Certificate | PTB 01 ATEX 2171 | 2001-11-26 | ⊕ II 2 G EEx ia IIC T6, Type 3766-1 |
| Statement of Conformity | PTB 01 ATEX 2195 X | 2002-03-07 | ⊕ II 3 G EEx nA II T6, Zone 2, Type 3766-8 |
| IECEX approval | IECEX TSA 05.0004X | 2005-05-24 | Ex ia I/IIC T6 IP 65, Ex nl/IIC T6 IP 65, without solenoid valve module with inductive limit switches, Type 3766-6 |
| GOST certificate | POCC DE GB05.B02637 | 2009-02-26 | Ex approval; valid until 2012-02-26 |
| CSA approval | 1607848 | 2005-09-16 | Ex ia IIC T6; Class I, Zone 0 Class I, Div. 1, Groups A, B, C; Class III Solenoid valve, position transmitter, inductive limit switches Type 3766-3 |
| FM approval | 3020228 | 2005-07-21 | Class I, II, III Div. 1; Groups A, B, C, D, E, F, G Cl. I, Zone 0 AEx ia IIC T6; Cl. I, Div. 2, Gr. A, B, C, D Cl. II; Div. 2, Gr. F, G; Cl. III; NEMA 4X; with position feedback, solenoid valve, inductive limit switches Type 3766-3 |

Refer to Data Sheet T 6116 EN for EEx d approvals for Type 6116 i/p Converter (Fig. 2)

Summary of explosion protection approvals for Type 3767 Positioner

| Type of approval | Certificate number | Date | Comments |
|---|--------------------|--------------------------|---|
| EC Type Examination Certificate | PTB 01 ATEX 2167 | 2001-11-29 | ⊕ II 2 G EEx ia IIC T6; Type 3767-1 |
| Statement of Conformity First Addendum | PTB 01 ATEX 2170 X | 2002-03-07 2003-05-28 | ⊕ II 3 G EEx nA II T6; Zone 2; Type 3767-8 |
| IECEX approval | IECEX TSA 05.0004X | 2005-05-24 | Ex ia I/IIC T6 IP 65, Ex nl/IIC T6 IP 65, without solenoid valve module with inductive limit switches, Type 3767-6 |
| GOST certificate | PPC 00 19324 | 2009-02-26 | Ex approval; valid until 2012-02-26 |
| CSA approval | 1607848 | 2005-09-16 | Ex ia IIC T6; Class I, Zone 0 Class I, Div. 1, Groups A, B, C; Class III Solenoid valve, position transmitter, inductive limit switches Type 3767-3 |
| FM approval | 3020228 | 2005-07-21 | Cl. I, II, III, Div. 1; Gr. A, B, C, D, E, F, G Cl. I, Zone 0 AEx ia IIC T6; Cl. I, Div. 2; Gr. A, B, C, D Cl. II, Div. 2; Gr. F, G; Cl. III; with position feedback, solenoid valve, inductive limit switches; Type 3766-3 |
| JIS approval | C-13674 | 2005-07-09 | Ex ia IIC T6; Type 3767-7 |
| KOSHA | 2007 2182 Q1 | 2007-10-31 | Ex ia IIC T6; Type 3767-1; valid until 2012-10-30 |

Article code

| Pneumatic Positioner | Type 3766- | | | | | | | | | | | | | |
|--|------------|---|---|---|---|---|---|---|---|---|---|---|---|---|
| | x | x | x | 0 | 1 | x | x | x | x | 1 | x | 0 | x | 0 |
| Explosion protection | | | | | | | | | | | | | | |
| Without | 0 | | | | | | | 2 | | | | | | |
| ⊕ II 2 G EEx ia IIC T6 acc. to ATEX | 1 | | | | | | | | | | | | | |
| FM/CSA intrinsically safe / non incendive | 3 | | | | | | | | | | | | | |
| Ex ia / Ex n I/IIC T6 IP 65 IECEx TSA Australia | 6 | | | | | | | | | | | | | |
| ⊕ II 3 G EEx nA II T6 acc. to ATEX | 8 | | | | | | | | | | | | | |
| Additional equipment | | | | | | | | | | | | | | |
| Without | 0 | | | | | | | | | | | | | |
| Limit switch, inductive, 2x SJ2 SN | 2 | | | | | | | | | | | | | |
| Analog position transmitter 4 to 20 mA | 6 | 0 | | | | | | | | | 0 | | | |
| 3/2-way solenoid valve | | | | | | | | | | | | | | |
| Without | | | 0 | | | | | | | | | | | |
| 6 V DC | | | 2 | | | | | | | | | | | |
| 12 V DC | | | 3 | | | | | | | | | | | |
| 24 V DC | | | 4 | | | | | | | | | | | |
| Pneumatic connections | | | | | | | | | | | | | | |
| ¼-18 NPT | | | | | | 1 | | | | | | | | |
| ISO 228/1 - G ¼ | | | | | | 2 | | | | | | | | |
| Electrical connections | | | | | | | | | | | | | | |
| Without (without additional equipment, without solenoid valve) | 0 | 0 | | | | 0 | 0 | | | | | | | |
| Cable gland | | | | | | | | | | | | | | |
| M20 x 1.5, blue (plastic) | | | | | | 1 | 0 | | | | 0 | | | |
| M20 x 1.5, black (plastic) | | | | | | 2 | 0 | | | | 0 | | | |
| M20 x 1.5 (nickel-plated brass) | | | | | | 2 | 1 | | | | 3 | | | |
| Housing version | | | | | | | | | | | | | | |
| Die-cast aluminum | | | | | | | | | | 0 | | | | |
| Stainless steel (CrNiMo) | | | | | | | | | | 2 | | | | |
| Temperature range | | | | | | | | | | | | | | |
| Standard | | | | | | | | | | | | 0 | | |
| Low temperature | | | | | | | | | | | | | | |
| T _{min} ≥ -50 °C; optional limit switches, solenoid valve | | | | | | 2 | 1 | | | | 3 | | | |
| Special version | | | | | | | | | | | | | | |
| None | | | | | | | | | | | | 0 | 0 | 0 |
| GOST approval | 1 | | | | | | | | | | | 0 | 1 | 0 |

Device functioning only as analog position transmitter: 3766-x60 000xxx00 000 0

Article code

| Electropneumatic Positioner | Type 3767- | | | | | | | | | | | | | |
|--|------------|---|---|---|---|---|---|---|---|---|---|---|---|---|
| | x | x | x | 0 | 1 | x | x | x | x | x | x | 0 | x | 0 |
| Explosion protection | | | | | | | | | | | | | | |
| Without | 0 | | | | | | 2 | | | | | | | |
| ⊗ II 2 G EEx ia IIC T6 acc. to ATEX | 1 | | | | | | | | | | | | | |
| FM/CSA intrinsically safe/non incendive | 3 | | | | | | | | | | | | | |
| ⊗ II 3 G EEx nA II T6 acc. to ATEX | 8 | | | | | | | | | | | | | |
| Additional equipment | | | | | | | | | | | | | | |
| Without | 0 | | | | | | | | | | | | | |
| Limit switch, inductive, 2x SJ2 SN | 2 | | | | | | | | | | | | | |
| Analog position transmitter 4 to 20 mA | 6 | 0 | | | | | | | | | | | | |
| 3/2-way solenoid valve | | | | | | | | | | | | | | |
| Without | | | 0 | | | | | | | | | | | |
| 6 V DC | | | 2 | | | | | | | | | | | |
| 12 V DC | | | 3 | | | | | | | | | | | |
| 24 V DC | | | 4 | | | | | | | | | | | |
| Type of mounting | | | | | | | | | | | | | | |
| Standard range spring | | | | 0 | 1 | | | | | | | | | |
| Pneumatic connections | | | | | | | | | | | | | | |
| ¼-18 NPT | | | | | | 1 | | | | | | | | |
| ISO 228/1 - G ¼ | | | | | | 2 | | | | | | | | |
| Electrical connections | | | | | | | | | | | | | | |
| Cable gland | | | | | | | | | | | | | | |
| M20 x 1.5, blue (plastic) | | | | | | | 1 | 0 | | | | | | |
| M20 x 1.5, black (plastic) | | | | | | | 2 | 0 | | | | | | |
| M20 x 1.5 (nickel-plated brass) | | | | | | | 2 | 1 | | | | | | |
| Housing version | | | | | | | | | | | | | | |
| Die-cast aluminum | | | | | | | | | 1 | | | | | |
| Stainless steel (CrNiMo) | | | | | | | | | 2 | | | | | |
| Reference variable | | | | | | | | | | | | | | |
| 4 ... 20 mA | | | | | | | | | | 1 | | | | |
| 0 ... 20 mA | | | | | | | | | | 2 | | | | |
| 1 ... 5 mA | | | | | | | | | | 3 | | | | |
| Temperature range | | | | | | | | | | | | | | |
| Standard | | | | | | | | | | | 0 | | | |
| Low temperature | | | | | | | | | | | | | | |
| T _{min} ≥ -45 °C; optional limit switches, solenoid valve | | | | | | 2 | 1 | | | 2 | | | | |
| Special version | | | | | | | | | | | | | | |
| None | | | | | | | | | | | | 0 | 0 | 0 |
| GOST approval | 1 | | | | | | | | | | | 0 | 1 | 0 |

Ordering text

Pneumatic Positioner Type 3766

or

Electropneumatic Positioner Type 3767

Accessories

- Adapter NPT for electrical connections
- Range spring 2

Additional specifications

- Without/with pressure gauge for output signal pressure and supply air

For mounting to the control valve:

- Reference variable preset

Operating direction: Increasing/increasing or increasing/decreasing

- Positioner with inductive limit switches:

Metal tag outside the pick-up field – Contact closed/

Metal tag inside the pick-up field – Contact open

- Direct attachment to Type 3277 Actuator (120 to 700 cm²)
- Attachment acc. to IEC 60534-6 (NAMUR)

Travel: ... mm, if applicable, rod diameter: ... mm

- Attachment to Type 3278 Rotary Actuator (160 or 320 cm²)
- Attachment to rotary actuators acc. to VDI/VDE 3845, single-acting or double-acting
- Linear or equal percentage valve characteristic
- Opening angle 70°/75°/90°

Refer to the Mounting and Operating Instructions EB 8355-1 EN (for Type 3766) or EB 8355-2 EN (for Type 3767) concerning the mounting parts required when the positioner is delivered unattached to a control valve.

Specifications subject to change without notice



SAMSON AG · MESS- UND REGELTECHNIK
Weismüllerstraße 3 · 60314 Frankfurt am Main · Germany
Phone: +49 69 4009-0 · Fax: +49 69 4009-1507
Internet: <http://www.samson.de>

T 8355 EN

2010-02